

READ THESE INSTRUCTIONS BEFORE YOU BEGIN INSTALLATION!

These sensors are designed for the purpose of monitoring the total amount of available light. A 4-20 mA or resistance output is then sent to your DDC control system or lighting controller. Since the ACI/LLS does not have a linear output, the ACI/LLS-T's 4-20 mA signal also has a non-linear output and shouldn't be used in applications where critical control of lighting is necessary. Some of the most common applications for the ACI/LLS and ACI/LLS-T are Outdoor Lighting, Signs, Light Posts, Entry Ways, and many more.

■ MOUNTING

The ACI/LLS, is designed to be mounted in a weatherproof enclosure with 1/2" NPT threads. All ACI/LLS-T transmitters will be snap-track mounted.

■ WIRING DIAGRAM

ACI/LLS

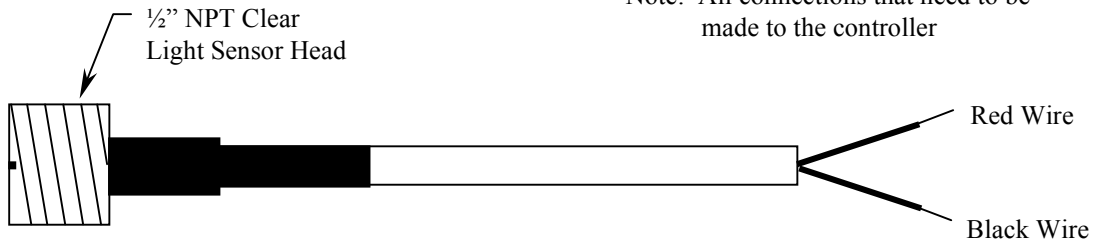

ACI/LLS-T

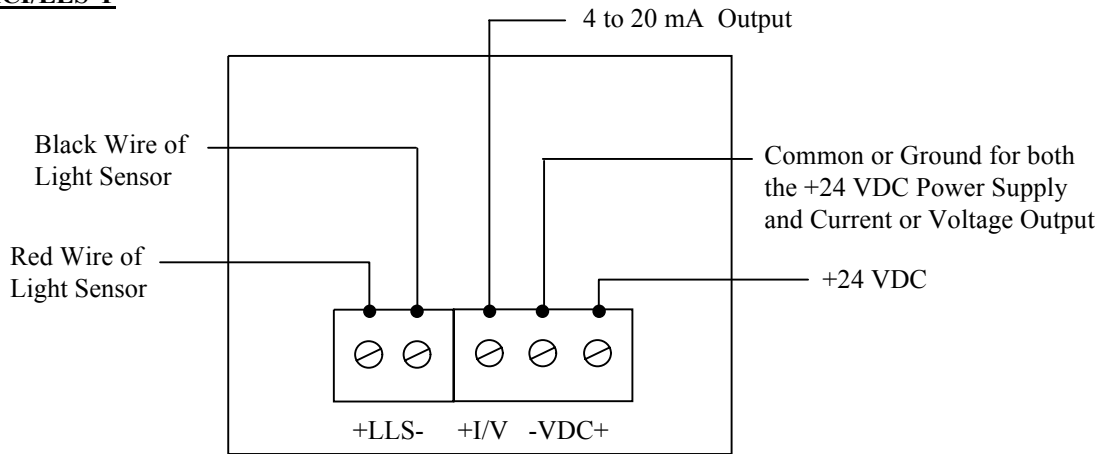

■ WIRING CONNECTIONS

- +VDC: +24 VDC Supply Voltage
- VDC: Ground or common
- I/V: Current or Voltage output
- +LLS: Red wire of sensor
- LLS: Black wire of sensor

The ACI/LLS-T must be powered with a 24VDC power supply, making sure to connect the wires to the correct terminal blocks since the units are polarity sensitive. Note that the ACI/LLS-T is not a loop-powered device, therefore a total of (3) wires must be used to send the signal back to the DDC Control System.

The ACI/LLS is calibrated for 20mA in bright light and 4mA in total darkness and is current limited to 22mA.